

Canadian Association of Rally Obedience
Working Handbook - 2015

Working
Level
Handbook
2015

Rules and Regulations



Published January 2015

Table of Contents

Description	2	Elite Level Exercises – Course Layouts	17
Equipment	3	WT1 - Drop & Sit on Recall - Elite	18
Club Supplied Equipment	3	WT2 - Retrieve on Flat - Elite	19
Boxes & Lines	3	WT3 - Barrel Racing - Elite	20
Handler box	3	WT4 - Directed Jumping - Elite	21
Dog Box (also known as the Target Area)	3	WT5 - Designated Retrieve - Elite	22
Distance Markings	3	WT6 - Back Away - Elite	23
Signs	3	WT7 - Round the Clock - Elite	24
Cones	3	WT8 - Distance Signals - Elite	25
Jumps	3	WT9 - Retrieve Over Jump - Elite	26
Tongs	3	WT10 - Scent Discrimination - Elite	27
Handler Supplied Equipment	3	Expert Level – Course Layouts	28
Measurements/Distance	4	WX1 - Drop & Sit, Call & Stand on Recall - Expert	29
Start & End of the Exercises	4	WX2 - Retrieve on Flat - Expert	30
Timing	4	WX3 - Barrel Racing - Expert	31
Walk Through	4	WX4 - Directed Jumping - Expert	32
Cues	4	WX5 - Designated Retrieve - Expert	33
Placement of objects	4	WX6 - Back Away – Expert	34
Choice of Objects/Tricks/Jumps	4	WX7 - Round the Clock - Expert	35
Food	4	WX8 - Distance Signals - Expert	36
Repeat of Stations	4	WX9 - Retrieve Over Jump - Expert	37
Order of Exercises	4	WX10 - Scent Discrimination - Expert	38
Movement in boxes	4	JUDGING:	39
Named Tricks	5	Training in the Ring	39
Scoring	5		
Close Proximity	5		
Multiple Choice	5		
Entries	5		
Rookie Level – Course Layouts	6		
WR1 - Drop on Recall - Rookie	7		
WR2 - Retrieve on Flat - Rookie	8		
WR3 - Barrel Racing - Rookie	9		
WR4 - Directed Jumping - Rookie	10		
WR5 - Designated Retrieve - Rookie	11		
WR6 - Back Away - Rookie	12		
WR7 - Round the Clock - Rookie	13		
WR8 - Distance Signals - Rookie	14		
WR9 - Retrieve Over Jump - Rookie	15		
WR10 - Scent Discrimination - Rookie	16		

CARO WORKING COMPETITION

Description

The Working Competition is not an entry level program. It requires off leash control and the ability of the dog to work under distracting conditions.

There are three divisions in the Working Competition - Rookie, Elite and Expert. Each of the three divisions is split into two subdivisions of five exercises.







SUBDIVISION I

Rookie	Elite	Expert
Drop on Recall	Drop on Recall	Drop on Recall
Retrieve on Flat	Retrieve on Flat	Retrieve on Flat
Barrel Racing	Barrel Racing	Barrel Racing
Directed Jumping	Directed Jumping	Directed Jumping
Designated Retrieve	Designated Retrieve	Designated Retrieve
CWRI	CWTI	CWXI

SUBDIVISION II

Rookie	Elite	Expert
Back Away	Back Away	Back Away
Round the Clock	Round the Clock	Round the Clock
Distance Exercises	Distance Exercises	Distance Exercises
Retrieve over Jump	Retrieve over Jump	Retrieve over Jump
Scent Discrimination	Scent Discrimination	Scent Discrimination
CWRII	CWTII	CWXII

There are six titles available to be awarded:

 CARO Working Rookie Class I	CWRI
 CARO Working Elite Class I	CWTI
 CARO Working Expert Class I	CWXI
 CARO Working Rookie Class II	CWRII
 CARO Working Elite Class II	CWTII
 CARO Working Expert Class II	CWXII

In order to qualify for a Working Title a dog and handler team must obtain 3 passing scores, under two different Judges, in each of the 5 exercises at the subdivision level at which they are competing.

The team does not have to pass all five exercises at once. Any exercises passed will be credited to the dog. For example, if a team passes exercise 1 and 3 but fails 2, 4 and 5 then the dog will receive credit for exercise 1 and 3.

Dogs must have a CARO RallyO Advanced title OR have successfully completed the Working Proficiency Test before competing in the Working Competition. See [Working Proficiency Test Handbook](#) for full requirements.

Dogs may compete in more than one level at a trial but any achievements obtained without first obtaining a pre-requisite will not be credited to the dog. If the pre-requisite is obtained at the same trial as the more advanced exercises then the successes at the more advanced level will be credited. All dogs must be off leash at this level but must enter and leave the ring on leash. Failure to comply with this will result in a FAIL as will leaving the ring during an exercise.

Progression through the Exercises. – There are four ways to progress through the exercises.

1. You may compete by sub-division, that is, you complete Rookie, then Elite then Expert at the subdivision I. You then complete Rookie, Elite and Expert at subdivision II.
2. You may compete by class, that is, you complete the Rookie classes at subdivision I then the Rookie classes at subdivision II. You then go on to Elite at subdivision I and then subdivision II and finally go on to Expert at subdivision I and subdivision II.
3. You may complete an individual exercise for example Drop on Recall at the Rookie, then Elite and then Expert levels.
4. Finally you may use any combination of the above. This progression gives both the handler and dog team and the host club the most opportunity for promoting the Working competition.

In all progressions, it is important to remember that you must have obtained the pre-requisite for the exercise you are attempting.

Equipment

In both sub-divisions of the working class, certain equipment is required, some of which is provided by the host club and some by the handler.

Club Supplied Equipment

- Handler Box (es)
- Handler Line (es)
- Dog Box (es)
- Back Away Box/Markings
- Distance Markings
- Cones
- Exercise Signs
- Jumps
- Tongs
- Cards for drawing of exercises **

** Judges may prefer to use their own cards. It is imperative that the Judge and the Host organisation agree as to who will be responsible for the cards.

Boxes & Lines

All boxes and lines may be constructed of white ½ inch diameter PVC, tape, nylon webbing or similar material. The boxes shall be taped or fixed in all four corners when used indoors so that they do not move. When used outdoors the boxes must be staked.

Heavier materials, such as steel, may also be used. In this case, they need not be taped or staked but they must be painted white.

Handler box

A square box to designate the Handler's position is required. The internal measurement of this box shall be approximately 2 feet x 2 feet. In some exercises, where indicated in the description, a line may be used to designate an area the handler must not cross. Where a line is used, it must be no more than two feet in length.

Dog Box (also known as the Target Area)

There are two target areas for dogs. One, where the dog backs into the area, and the other, where the dog either moves directly to it or is left in it. Both types of boxes shall be 3 sided. The interior measurement of the boxes shall be approximately four (4) feet by four (4) feet. **For Back Away exercises** the open end of the box shall be placed so that it is closest to the handler. For all other exercises the closed end of the box shall be placed so that the closed end is closest to the handler.

Clubs are advised to have more than one of each box available for a trial. Liaison with the Judge(s) will ensure that the host club has the requisite equipment available.

Distance Markings

Markings must be placed at the required distance with tape, chalk or similar on the floor either to the right of or in the path of the dog and handler.

Signs

The sign for the various changes of position must be placed where the handler can easily read the signal exercises. The sign may be placed over the station sign or on a separate sign holder. The dimension of the sign is 8 x10 and lettering should be of the large font to be easily read. (see example page 11) In places where the space is limited, one sign holder is sufficient.

Cones

For better visibility, the cones used in working should be a **minimum** 18" tall. Either an 18" cone may be used or a cone of lesser height with an addition that brings the visible height to 18". If using smaller cones, a hole may be drilled into the top of the cone and a dowel may be inserted into the cone to obtain the required 18 inches. The dowel shall be painted white and striped with a dark colour.

Jumps

Standard jumps (solid or bar) may be used as detailed in the Master General Handbook. The jump heights will be those specified in the Master General Handbook

Tongs

Tongs must be used when handling ALL objects.

Handler Supplied Equipment

Depending upon the exercises being performed, the handler will be required to supply objects as described in this manual for the retrieve, designated retrieve and scent discrimination exercises. The handler will provide all the objects required for the working level and hand them to the ring steward prior to entering the ring. These objects must be placed in a basket or carrier provided by the handler. The ring steward will place them in a holding location (a table, chair, wall etc.) provided for the objects, taking care not to leave any scent on the objects. It is important that the objects are handled in a manner as not to spoil the scent. The objects should be placed in a container so that they are not visible to the dog prior to the commencement of the exercise.

Canadian Association of Rally Obedience Working Handbook - 2015

Measurements/Distance

Where distance between the handler box or line and the target box is concerned, the measurement is taken from the front of the handler's box (or line) to the front of the target box i.e. the shortest distance between the two boxes.

Where a disability of the handler is such that an object cannot be thrown the required distance either, at the choice of the handler, the Judge or Steward may place the object in an appropriate position OR the handler may tell the dog to stay and then move forward to a position where the object may be thrown successfully. The handler will then return to the dog to continue the exercise.

Start & End of the Exercises

The exercises will begin when the Judge gives the handler permission to start. The exercises will end when the handler has completed the last station.

Timing

Maximum time allowed depends upon the level of competition (Rookie – 5 minutes, Elite & Expert 10 minutes) which commences when the Judge indicates the first station may be attempted. Time is stopped when the last exercise is completed or when the timer calls time at the expiration of the maximum time. The handler must leave the ring when time is called.

The handler may choose not to complete an exercise and move on to the next one. The handler will indicate the decision not to complete an exercise but time will continue to run (unless this is the last exercise). This will result in a FAIL for the exercise not completed.

Walk Through

A two (2) minute walkthrough for each 10 competitors will be allowed.

Cues

When specific cues are used in this handbook (e.g. 'get it'), they are given as an example only. Any suitable cue may be used by the handler unless such cues are specified as not permissible. Verbal cues and hand signals may be given simultaneously and may be repeated except where prohibited in a specific exercise.

Handlers of dogs that are deaf may use hand

signals even though the exercise prohibits this.

Placement of objects

The ring steward or Judge will place the objects in the designated location once the handler has arrived at the station. Once the exercise is completed, the ring steward will remove the objects and return them to the holding location.

Choice of Objects/Tricks/Jumps

When a station requires a choice to be made, the handler will draw a card from a series of cards that will indicate what is to be performed. In this manner, no advantage is given to any competitor.

Food

No food is allowed in the Working Level.

Repeat of Stations

Training in the ring is not permitted.

In the Working Rookie and Elite Levels one repeat of each station is allowed. The Judge should indicate to a handler if an exercise has not been performed to obtain a PASS or if the exercise is a PASS.

It is the judge's responsibility to tell the competitor to "move on" to the next attempt at the exercise or to the next exercise after the second attempt. (see page 41)

Order of Exercises

Unlike the general classes, there is no set pattern in the working level. **The exercises may be performed in the order of the handler's choosing.**

Movement in boxes

Both handlers and dogs may move within their respective boxes but any movement outside will result in a FAIL for the exercise (but see the Distance Exercises for the exception). Should the handler leave the handler box, even by moving one of his/her feet out of the box, it will result in a FAIL. If the handler line is utilized then the handler must remain behind the line and within the plane of the line.

Named Tricks

In the Distance exercises, at the Elite II level, a trick may have to be performed. One trick must be performed at the Expert II level. Three tricks to be performed at the Expert level. Handler may choose from the following list of allowable tricks.

Sit Pretty (Beg)	Speak
Roll Over	Wave
Bow	Spin Left or Right
Crawl Forwards **	Scout Backwards **

**** Must be at least one body length**

Scoring

Scoring in the Working level will be based upon PASS/FAIL. In order to PASS a dog must successfully complete all of the principal features of the exercise. Dogs will not be judged for heeling at this level but the dog must be under control at all times, and in close proximity to the handler. If a dog leaves the ring it will FAIL. If the dog does not maintain close proximity then depending upon the degree it may FAIL. If a dog leaves the handler to go to another station but returns when recalled, this is permissible. A `finish` is generally not required but may be completed if so desired – it will not be subject to a PASS/FAIL unless the dog is not within Close Proximity.

Any anticipation on the part of the dog will result in a FAIL for any exercise.

Close Proximity

Close Proximity is defined as the handler being able to touch the dog's head or body. In the case of small dogs, the handler should be able to achieve this by bending down. The handler may use verbal and hand signals cues either simultaneously or separately when needed to achieve this position. As in the general classes, dogs may work on the left or right hand side of the handler.

Multiple Choice

Some exercises may require a variety of events which will be decided by draw by the handler. For example, in the Distance Signals exercises, a number of different position changes are required. The draw from cards (or something similar) will be made before the handler enters the ring unless indicated otherwise in the exercise. Each handler will draw a card, i.e. not all dogs will necessarily jump the same jump. Duplicate cards could be made available so that both the Judge and the handler may have a copy or the Judge may make a notation on the score sheet. Drawn cards shall be made available for the next competitor.

Entries

An event at a working trial consists of five exercises. Typically these exercises will all be in the same subdivision (i.e. Rookie, Elite or Expert). Clubs may hold two working trials under one event number. The two trials may be either at the same level (i.e. Rookie and Rookie) OR at adjoining levels (i.e. Rookie and Elite) OR at adjoining subdivisions (Subdivision I Rookie and Subdivision II Rookie). A competitor may enter 5 exercises in two adjacent subdivisions. One entrant may want to compete in WR1, WR2, WR4 and WT3 and WT5. Another entrant may wish to compete in a different five exercises. The manner in which these exercises are performed will be determined by the host organisation: One method would be to allow the Rookie exercises to be completed and timed and then have the ring reset for the Elite exercises. Timing of these split classes will be of importance. Currently the Rookie classes are allowed five minutes and the other classes ten minutes. Each exercise will be allotted a percentage of time allowed at the respective level, that is a Rookie exercise will be allotted one minute and the other level exercises will be allowed two minutes. If the Rookie exercises take less time than the time allotted, the spare time will not carry over to the Elite classes.

Rookie Level - Course Layouts

<p>WR1 - Drop on Recall</p>	<p>WR2 - Retrieve on the Flat</p>	<p>WR3 - Barrel Racing</p>
<p>WR4 - Directed Jumping</p>	<p>WR5 - Designated Retrieve</p>	<p>WR6 - Back Away</p>
<p>WR7 - Round the Clock</p>	<p>WR8 - Distance Signals</p>	<p>WR9 - Retrieve Over Jump</p>
<p>WR10 - Scent Discrimination</p>		<p><i>These diagrams are for illustration purposes only. They are not to scale and do not necessarily display accurately the actual layout</i></p>

WR1 - Drop on Recall - Rookie

DESCRIPTION

This exercise demonstrates a dog's willingness to drop on cue at a designated location and eagerly return to the handler on cue.

THE PRINCIPLE FEATURES OF THIS EXERCISE ARE FOR THE DOG:-

- To stay in position until cued to move forward.
- To move towards the handler until cued to drop.
- To drop in a designated area with both elbows down and behind the drop line closest to the handler until cued to move forward.
- To move to the front position when cued and sit close enough that the handler, without moving his/her feet forward, may touch the dog on the head.

COURSE LAYOUT

The total distance from the dog box to the handler box or line will be 20'. Markers are situated 10' and 5' from the handler.

The markers shall be tape or lines on the floor in the path of the dog and handler. The drop zone is between the 10' and 5' markers.

Sign WR1 shall be placed in such a position that it may be easily seen by the handler but will not interfere with other exercises.

PROCEDURE

The handler sits the dog in the dog box. The handler may cue the dog to stay and then proceeds to the handler box. The handler turns to face the dog. The handler then, without prompting from the Judge, calls the dog and then cues the dog to drop within the "drop zone". Once the dog has completed the drop, the handler will call the dog to the front position.

This exercise is completed with the dog sitting in the front position.

WR2 - Retrieve on Flat - Rookie

DESCRIPTION

This exercise demonstrates a dog's willingness and ability to retrieve an object.

THE PRINCIPLE FEATURES OF THIS EXERCISE ARE FOR THE DOG:-

- To sit at heel position and stay there while the handler throws an object and it stops moving.
- Upon cue from the handler, to retrieve the object.
- To sit in front of the handler close enough that the handler does not have to move his/her feet to accept the object.
- To deliver the object to the hand of the handler.

COURSE LAYOUT

A handler box or line will designate the starting position.

A cone or similar marker may be placed to one side of the desired 'throw' area at a distance of 5' from the handler box or line.

PROCEDURE

An inactive toy or item of the handler's choice may be used. It may not be a toy or item that easily rolls when thrown (such as a ball) and it must not make any internal noise (squeak or growl etc.). If the object is not meant to roll but it does (such as a dumbbell, Frisbee or other toy) that is permitted.

The handler may use voice & hand signals simultaneously throughout the exercise.

The handler sits the dog in heel position. If a handler box is utilised, it is not necessary for the dog to be in the handler box but the feet of the dog must be behind the front of the handler box. If a handler line is used, the feet of both the handler and the dog must be behind the line.

The handler may cue the dog to stay.

Without instruction from the Judge, the handler will throw the object at least 5'.

When the object has stopped moving the handler will cue the dog to retrieve the object.

Praise may be offered only when the dog has successfully retrieved the object and is returning to the handler. The dog will retrieve the object and sit in front of the handler to deliver the object.

The exercise is complete when the object is delivered. No finish is required.

WR3 - Barrel Racing - Rookie

DESCRIPTION

This exercise demonstrates the dog's ability and willingness to work away from the handler and to take direction.

THE PRINCIPLE FEATURES OF THIS EXERCISE ARE FOR THE DOG:-

- To sit at heel position until directed by the handler to circle around a series of cones.
- To circle the cones in the correct direction.
- To return to the handler, close enough to be touched, after all cones have been circled. Note: The handler may rotate in place but must not step out of the handler box.

COURSE LAYOUT

Three cones are placed. Cones 1 and 2 are set 10 feet apart. Cone 3 is set 5 feet from an imaginary line drawn perpendicular from the midway point between cones 1 and 2. The front of the handler box will be 7 (seven) feet from cone 3.

PROCEDURE

The exercise will start with the dog sitting in heel position.

The handler will send the dog without prompting from the Judge. Handler may use arms and/or hands or voice as directional cues.

The exercise is complete when the dog has circled all cones correctly and returned close enough to the handler to be touched.

Direction of travel (Handler's Choice)

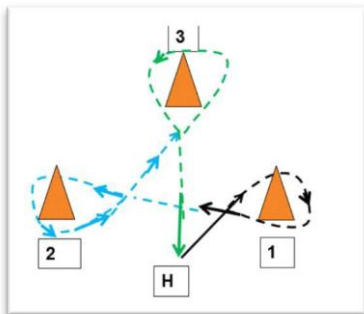

The dog is sent in a clockwise direction around Cone #1, then sent in an anti clockwise direction around cone # 2, then also in an anticlockwise direction around cone # 3 and back to the handler

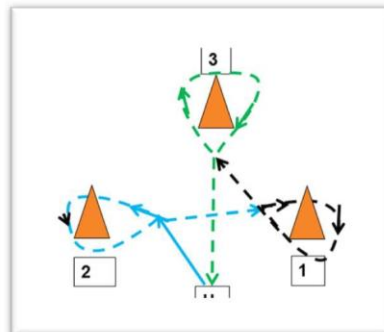

The dog is sent in an anti-clockwise direction around Cone #2, then sent in a clockwise direction around cone # 1, then also in a clockwise direction around cone # 3 and back to the handler

WR4 - Directed Jumping - Rookie

DESCRIPTION

This exercise demonstrates the dog's ability to move away from the handler, take instructions and then jump a designated jump.

THE PRINCIPLE FEATURES OF THIS EXERCISE ARE FOR THE DOG:-

- To sit at heel position and stay there until cued by the handler to move.
- To move between two jumps towards a target area.
- To be in the dog box before turning.
- To sit, stand or lie down in the dog box until cued to jump.
- To jump the correct jump.
- To sit close enough in front of the handler so that the handler, without moving his/her feet forward, may touch the dog on the head.

COURSE LAYOUT

Two Jumps are required for this exercise. These jumps may be either 2 bar jumps, 2 solid jumps, or one of each. The jumps will be placed side by side, in line, with a distance of 15' (feet) between the two nearest jump uprights. A handler box is placed 15' (feet) in front of the jump and midway between the 2 jumps. A dog box is placed midway between the two jumps and 15' (feet) beyond the jumps and 30' (feet) from handler.

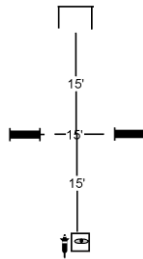

PROCEDURE

The handler may choose to walk with the dog to the "dog box" to familiarize the dog as to the location of the box and the construction of the box. This may be done at the start of the Class or just prior to each exercise. There will not be any additional time allowed should the handler choose to familiarize the dog to the box.

The exercise starts at the handler box, with the dog sitting in heel position. Without leaving the box the handler, without prompting from the Judge, sends the dog away and forward in a direct line between the two jumps to the dog box 30' (feet) from the handler. Once the dog is in the box, the handler may cue the dog to turn to him/her and may then cue the dog with verbal and hand cues simultaneously to assume a sit, stand or down position in the dog box.

Hand and voice signals may be used simultaneously to indicate to the dog which jump to take. Handler may use an additional cue such as "hup" or "over" as the dog approaches the jump. Handler may turn to face the dog as he/she comes over the designated jump.

Dog is required to sit in front. No Finish is required.

Only one jump is attempted at this level.

The exercise is completed when the dog has successfully jumped the correct jump and sits in front of the handler.

CHOICE OF JUMP

The choice of which jump is to be attempted will be made by the Judge prior to the first dog entering the ring and will be the same for all dogs.

WR5 - Designated Retrieve - Rookie

DESCRIPTION

This exercise demonstrates the dog's ability to retrieve a named object.

THE PRINCIPLE FEATURES OF THIS EXERCISE ARE FOR THE DOG:-

- To sit at heel position whilst three objects are placed in front of the dog.
- To retrieve the correct object when cued.
- To work briskly although reasonable time is allowed for the dog to select the object.
- To sit close enough in front of the handler so that the handler, without moving his/her feet, can accept the object.

Note: The handler may use verbal & signal cues to designate which object is to be retrieved. No additional cues may be used during the retrieve. The handler may turn towards the object of choice and point to the object of choice. Praise may be offered only after the dog has successfully retrieved the correct article and is returning to the handler.

COURSE LAYOUT

Three dissimilar objects or inactive toys of the handler's choice are placed 10 feet in front of the handler as depicted in the diagram below. The objects are placed 2 feet apart. No sound or light may be emitted from the objects and neither must they easily roll i.e. such as a ball but dumbbells are permitted. The objects should be of a size commensurate with that of the dog (small dog – small objects).



PROCEDURE

Upon entering the ring, the handler will give the objects to the Steward who will place the objects at a pre-determined location (chair, table or other suitable location) until needed.

Just prior to the commencement of the exercise the ring steward or Judge will place the 3 objects as required.

When the exercise begins, the handler stands in the handler box.

The handler, with the dog sitting in heel position, will face the objects.

The Judge or steward will have three cards marked 'Left', 'Centre' and 'Right'. The handler will draw one card to ascertain which object is to be retrieved.

The handler may then cue the dog to retrieve the named object.

Once given the cue, the dog must retrieve the object to the handler and sit in the front position to deliver. The dog does not have to be in the boxed area to deliver.

Praise may be offered only after the dog has successfully retrieved the correct article and is returning to the handler.

Upon the dog's return, the handler may cue the dog to release the object to hand.

The exercise is finished when the dog has delivered the object to hand.

WR6 - Back Away - Rookie

DESCRIPTION

This exercise demonstrates the dog's ability to walk backwards a short distance in a straight line.

THE PRINCIPLE FEATURES OF THIS EXERCISE ARE FOR THE DOG:-

- To sit or stand in front of the handler box with its back to the back-up box.
- When cued by the handler, to move backwards briskly into the back-up box.

COURSE LAYOUT

The shortest distance from the handler box to the back-up box will be 5' (feet).

PROCEDURE

The handler may choose to walk with the dog to the "dog box" to familiarize the dog as to the location of the box and the construction of the box. This may be done at the start of the Class or just prior to each exercise. There will not be any additional time allowed should the handler choose to familiarize the dog to the box.

The exercise begins with the dog/handler team stationary at the handler's box. The dog stands or sits facing the handler with the handler facing the back-up box.

Without prompting by the Judge, the handler will cue the dog to begin backing to the back-up box.

The dog should back away from the handler in a brisk manner.

The exercise is complete when the dog is in the back-up box.

WR7 - Round the Clock - Rookie

DESCRIPTION

This exercise demonstrates the dog's ability and willingness to work away from the handler, to take direction and to make correct choices.

THE PRINCIPLE FEATURES OF THIS EXERCISE ARE FOR THE DOG:-

- To circle three cones as directed by the handler.
- To circle each required cone once only.
- To return to the handler close enough to be touched after circling each cone
- To sit in front of the handler after circling all of the required cones.

COURSE LAYOUT

Six (6) cones will be placed a distance of 5 feet from the centre of the handler box in a circle. The cones will be evenly spaced around the circle. (at 2, 4, 6, 8,10, and 12 o'clock).

The cones will be numbered 1 through 6 with 2" high numbering with the numbers facing the centre of the circle.

PROCEDURE

The cones to be circled will be posted at ringside prior to the start of the competition. The exercise starts with the Handler standing within the handler box.

All dogs in a class will be required to circle the same cones. The cones may be attempted in any order.

Dog may circle a cone in either a clockwise or anticlockwise direction. No cone should be circled more than once.

The dog returns to the handler each time for a redirection to the next cone. No sit or physical contact is required.

The exercise is finished when the dog has successfully circled the three correct cones, returned to the handler and sat in front.

CONE LAYOUT

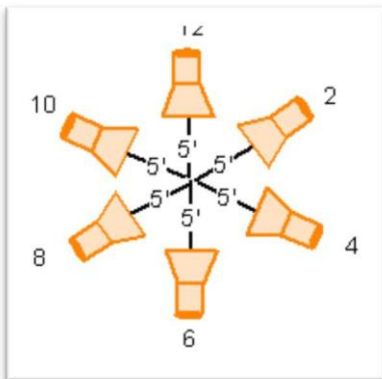

WR8 - Distance Signals - Rookie

DESCRIPTION

This exercise demonstrates the dog's ability to understand and perform exercises by physical signal alone.

THE PRINCIPLE FEATURES OF THIS EXERCISE ARE FOR THE DOG:-

- To sit and stay in position in the dog box whilst the handler walks away.
- To stay in position when the handler turns to face the dog.
- To correctly perform a series of positional changes and perform a 'spin'.
- To respond to non-verbal cues alone.
- To remain in the box whilst performing the positional changes.
- To return to the box if the 'spin' causes the dog to leave the box.

COURSE LAYOUT

There will be a handler box and a dog box.

The distance between the two boxes will be 5' (feet).

PROCEDURE

This exercise starts with the dog in heel position in the dog box.

Without prompting from the Judge, the handler cues the dog to sit & stay and then walks 5' (feet) away to the handler box.

The dog remains stationary in the dog box. The handler turns and faces the dog.

The handler will then cue the dog to perform the exercises. Both the handler and the dog remain in their respective boxes. Exercises must be performed in the order specified.

Exercises will be written/typed on slips of cardboard or paper or something similar and placed in a container in such a manner that the writing is not visible to the handler. Handler will draw, prior to entering the ring, to determine which one of the following set of exercises the dog must perform.

Dogs are allowed to leave their box during the required behaviour but should return to the box on completion of the required behaviour. The handler may cue the dog to return to the dog box after the required behaviour. The exercise is finished when the dog has completed the correct position changes & other behaviours and returned to the box.

Position Changes (Dog must perform one of the following as determined by the handler draw)

Sit to Stand +Stand to Down + Down to Sit + Sit to Stand + Spin Left. (Anticlockwise)

Sit to Stand +Stand to Down +Down to Stand + Stand to Sit+ Spin Right. (Clockwise)

Sit to Stand +Stand to Sit+ Sit to Down +Down to Stand + Spin Left. (Anticlockwise)

Sit to Stand +Stand to Sit + Sit to Down +Down to Stand + Spin Right. (Clockwise)

Sit to Down +Down to Stand + Stand to Sit + Sit to Stand+ Spin Left (Anticlockwise)

Sit to Down +Down to Stand + Stand to Sit + Sit to Stand+ Spin Right (Clockwise)

WR9 - Retrieve Over Jump - Rookie

DESCRIPTION

This exercise demonstrates the dog's ability to retrieve an object** and to jump both going to pick up and returning to deliver an object.

THE PRINCIPLE FEATURES OF THIS EXERCISE ARE FOR THE DOG:-

- To sit at heel position while the handler throws an object.
- To stay in the sit position until cued to jump/retrieve after the object is stationary.
- When cued, to jump over the jump and pick up the object.
- To return over the jump carrying the object.
- To sit in front of the handler close enough that the handler does not have to move his/her feet.
- To relinquish the object to the handler.

COURSE LAYOUT

A handler box or line is placed 10' (feet) away from a standard bar or solid jump (agility or obedience). The jump height will be as stated in the Advanced level of the regular classes.

PROCEDURE

The exercise begins with the handler standing in front of the jump in the handler box or behind the handler line. The handler may stand further back than the 10' line or box but the handler must remain in position.

Dog sits in heel position.

Without prompting from the Judge, the handler will throw the item over the jump while the dog waits in heel position. The item must be thrown at least 5' beyond the jump.

Once given the cue, the dog will go over the jump to get the object, and return to the handler, going over the jump a second time.

The handler may cue the dog to "Jump" then cue the dog to "Get It" and also cue the dog to return over the jump. The Handler may cue the dog to release the object to hand. Hand and voice signal can be used simultaneously. No finish is required.

The exercise is complete when the dog has delivered the object to hand.

** Any object of the handler's choice may be used. Description: it may not be a toy that easily rolls when thrown, (such as a ball) and it may not make any internal noise – squeak, growl, etc. If the object is not meant to roll and does so, such as a dumbbell, that is permitted.

WR10 - Scent Discrimination - Rookie

DESCRIPTION

The exercise demonstrates the dog's ability to detect one item with the handler's scent from other items without the handler's scent.

THE PRINCIPLE FEATURES OF THIS EXERCISE ARE FOR THE DOG:-

- To sit or stand in position with its back to the object placement area.
- Upon signal from the Judge will either
 - Turn with the handler to face the objects and sit at heel. When cued by the handler (without prompting from the Judge), will briskly move towards the objects and retrieve the object that has been scented by the handler OR.
 - Turn with handler and upon cue from the handler (without prompting from the Judge) will briskly move towards the objects and retrieve the object that has been scented by the handler (i.e. without having the dog sit after the turn).
- To return briskly and sit in front of the handler to deliver the object close enough that the handler does not have to move his/her feet to accept the object. No finish is required.

NOTE: During this exercise extra cues are not allowed. Praise may be offered after the dog has successfully retrieved the correct article and is returning to the handler.

COURSE LAYOUT

A handler box or line is required. Three objects are placed in a straight line 10' (feet) from the handler box as indicated in the diagram below and two feet apart.

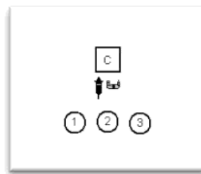

PROCEDURE

The handler will provide either three (3) clean cloth or three (3) leather gloves of a similar colour. Alternatively regular scent objects as used in obedience competition may also be used. Gloves should be of a size comfortable for the dog to carry i.e. Small dog - small glove.

Just prior to the commencement of the exercise the Steward will place the objects in a holding location (a chair) provided for the objects, taking care not to leave any scent on the objects. Tongs must be used to remove and place objects.

The handler will stand in the handler box.

The exercise begins with the handler, with the dog in heel position (either the sit or stand), having his/her back to the area where the objects shall be placed to begin the retrieval exercise.

The handler, with hands in sight, will impart his/her scent on one object. Two (2) remaining objects are unscented.

The ring steward or Judge will place the 3 objects in the manner described above.

Upon signal from the Judge-the handler may impart the scent again and then cue the dog to retrieve the object. No other hand signals or verbal signals may be given to the dog during the retrieve.

Praise may be offered only after the dog has successfully retrieved the correct article and is returning to the handler.

The handler may cue the dog to release the object to hand.

The handler may not turn towards the object of choice, point to the object of choice nor step towards the object.

The dog is required to retrieve ONE object only.

Elite Level Exercises – Course Layouts

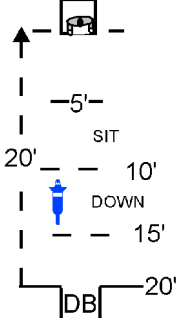
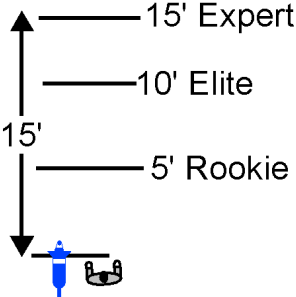
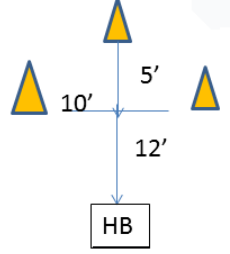
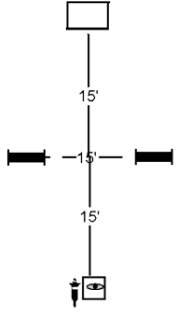
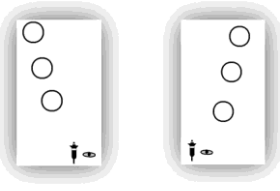
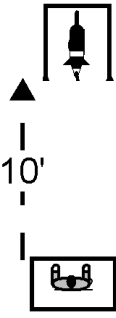
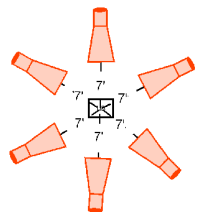
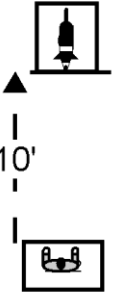
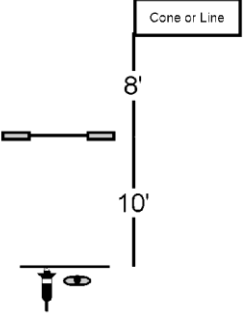
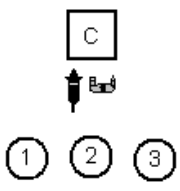
 <p>WT1 - Drop and Sit on Recall</p>	 <p>15' Expert 10' Elite 5' Rookie</p> <p>WT2 - Retrieve on the Flat</p>	 <p>WT3 - Barrel Racing</p>
 <p>WT4 - Directed Jumping</p>	 <p>WT5 - Designated Retrieve</p>	 <p>WT6 - Back Away</p>
 <p>WT7 - Round the Clock</p>	 <p>WT8 - Distance Signals</p>	 <p>WT9 - Retrieve Over Jump</p>
 <p>WT10 - Scent Discrimination</p>	<p><i>These diagrams are for illustration purposes only. They are not to scale and do not necessarily display accurately the actual layout</i></p>	

WT1 - Drop & Sit on Recall - Elite

DESCRIPTION

This exercise demonstrates a dog's willingness to drop on cue at a designated location, then to sit on cue at another location and then eagerly return to the handler on cue.

THE PRINCIPLE FEATURES OF THIS EXERCISE ARE FOR THE DOG:-

- To stay in position until cued to move forward.
- To move towards the handler until cued to drop.
- To drop in a designated area with both elbows down and behind the appropriate drop line until cued to move forward.
- To move towards the handler until cued to sit
- To sit in the designated area with front feet behind the drop line closest to the handler until cued to move forward
- To move to the front position when cued and sit close enough that the handler, without moving his/her feet forward, may touch the dog on the head.

COURSE LAYOUT

The total distance from the dog box to the handler box or line will be 20'.

Markers are situated 15', 10' and 5' from the handler.

The markers shall be tape or lines on the floor in the path of the dog and handler. The drop zone is between the 15' and 10' markers.

The sit zone is between the 10' and 5' markers.

Sign WT1 shall be placed in such a position that it may be easily seen by the handler but will not interfere with other exercises.

PROCEDURE

The handler sits the dog in the dog box. The handler may cue the dog to stay and then proceeds to the handler box or line.

The handler turns to face the dog.

The handler then, without prompting from the Judge, calls the dog and then cues the dog to drop within the "drop zone".

Once the dog has completed the drop, the handler calls the dog again and then cues the dog to sit within the "sit zone".

Once the dog has sat, the handler will call the dog to the front position. This exercise is completed with the dog sitting in the front position.

WT2 - Retrieve on Flat - Elite

DESCRIPTION

This exercise demonstrates a dog's willingness and ability to retrieve an object.

THE PRINCIPLE FEATURES OF THIS EXERCISE ARE FOR THE DOG:-

- To sit at heel position and stay there while the handler throws an object and it comes to rest.
- Upon cue from the handler, to retrieve the object.
- To sit in front of the handler close enough that the handler does not have to move his/her feet to accept the object.
- To deliver the object to the hand of the handler.

COURSE LAYOUT

A handler box or line will designate the starting position.

A cone or similar marker may be placed to one side of the desired 'throw' area at a distance of 10' from the handler box or line.

PROCEDURE

An inactive toy or item of the handler's choice may be used. It may not be a toy or item that easily rolls when thrown (such as a ball) and it must not make any internal noise (squeak or growl etc.). If the object is not meant to roll but it does (such as a dumbbell, Frisbee or other toy) that is permitted.

The handler may use voice & hand signals simultaneously throughout the exercise.

The handler sits the dog in heel position. If a handler box is utilised, it is not necessary for the dog to be in the handler box but the feet of the dog must be behind the front of the handler box. If a handler line is used, the feet of both the handler and the dog must be behind the line.

The handler may cue the dog to stay.

Without instruction from the Judge, the handler will throw the object at least 10'.

When the object has stopped moving the handler will cue the dog to retrieve the object.

Praise may be offered only when the dog has successfully retrieved the correct object and is returning to the handler.

The dog will retrieve the object and sit in front of the handler to deliver the object. The exercise is complete when the object is delivered.

No finish is required.

WT3 - Barrel Racing - Elite

DESCRIPTION

This exercise demonstrates the dog's ability and willingness to work away from the handler and to take direction.

THE PRINCIPLE FEATURES OF THIS EXERCISE ARE FOR THE DOG:-

- To sit at heel position until directed by the handler to circle around a series of cones.
- To circle the cones in the correct direction.
- To return to the handler, close enough to be touched, after all cones have been circled. Note: The handler may rotate in place but must not step out of the handler box.

COURSE LAYOUT

Three cones are placed. Cones 1 and 2 are set 10 feet apart. Cone 3 is set 5 feet from an imaginary line drawn perpendicular from the midway point between cones 1 and 2. The front of the handler box will be 12 (twelve) feet from cone 3.

PROCEDURE

The exercise will start with the dog sitting in heel position.

The handler may send the dog without prompting from the Judge. Handler may use arms and/or hands or voice as directional cues.

The exercise is complete when the dog has circled all cones correctly and returned close enough to the handler to be touched.

Direction of travel (Handler's Choice)

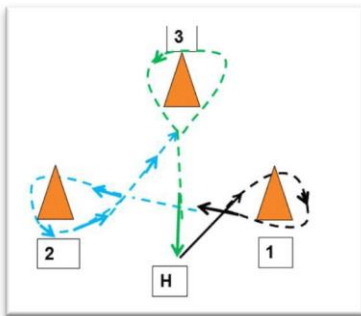

The dog is sent in a clockwise direction around Cone #1, then sent in an anti clockwise direction around cone # 2, then also in an anticlockwise direction around cone # 3 and back to the handler.
vvv

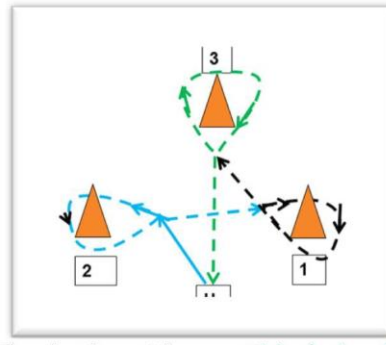

The dog is sent in an anticlockwise direction around Cone #2, then sent in a clockwise direction around cone # 1, then also in a clockwise direction around cone # 3 and back to the handler

WT4 - Directed Jumping - Elite

DESCRIPTION

This exercise demonstrates the dog's ability to move away from the handler, take instructions and then jump a designated jump and then to repeat the procedure.

THE PRINCIPLE FEATURES OF THIS EXERCISE ARE FOR THE DOG:-

- To sit at heel position and stay there until cued by the handler to move.
- To move between two jumps towards a target area.
- To be in the dog box before turning.
- To sit, stand or lie down in the dog box until cued to jump.
- To jump the correct jump.
- To sit close enough in front of the handler so that the handler, without moving his/her feet forward, may touch the dog on the head.
- To repeat the procedure for the second jump.

COURSE LAYOUT

Two Jumps are required for this exercise. These jumps may be either 2 bar jumps, 2 solid jumps, or one of each. The jumps will be placed side by side, in line, with a distance of 15' (feet) between the two nearest jump uprights. A handler box is placed 15' (feet) in front of the jump and midway between the 2 jumps. A dog box is placed midway between the two jumps and 15' (feet) beyond the jumps and 30' (feet) from handler.

PROCEDURE

The handler may choose to walk with the dog to the "dog box" to familiarize the dog as to the location of the box and the construction of the box. This may be done at the start of the Class or just prior to each exercise. There will not be any additional time allowed should the handler choose to familiarize the dog to the box.

The exercise starts at the handler box, with the dog sitting in heel position. Without leaving the box, the handler, without prompting from the Judge, sends the dog away and forward in a direct line between the two jumps, to the dog box 30' (feet) from the handler. Once the dog is in the box, the handler may cue the dog to turn to him/her and may then cue the dog with verbal and hand cues simultaneously to assume a sit, stand or down position in the dog box.

Hand and voice signals may be used simultaneously to indicate, to the dog, which jump to take. Handler may use an additional cue such as "hup" or "over" as the dog approaches the jump.

Handler may turn to face the dog as he/she comes over the designated jump.

Dog is required to sit in front. The handler may cue the dog to sit in front. No Finish is required. The handler may then cue the dog to the heel position for the second part of the exercise.

The dog will be required to be sent each time to the dog box for each of the jumps.

The exercise is completed when the dog has successfully jumped the jumps in the correct order and sits in front of the handler.

CHOICE OF JUMP

The order in which the jumps are to be attempted will be made by the Judge prior to the first dog entering the ring and will be the same order for all dogs.

WT5 - Designated Retrieve - Elite

DESCRIPTION

This exercise demonstrates the dog's ability to retrieve 2 named objects.

THE PRINCIPLE FEATURES OF THIS EXERCISE ARE FOR THE DOG:-

- To sit at heel position whilst three objects are placed in front of the dog.
- To retrieve the correct object when cued.
- To work briskly although reasonable time is allowed for the dog to select the object.
- To sit close enough in front of the handler so that the handler, without moving his/her feet, can accept the object.

Note: The handler may use verbal & signal cues to designate which object is to be retrieved. No additional cues may be used during the retrieve. The handler may turn towards the object of choice and point to the object of choice. Praise may be offered after the dog has successfully retrieved the correct article and is returning to the handler.

COURSE LAYOUT

Three dissimilar objects or inactive toys of the handler's choice are placed 10 feet in front of the handler as depicted in one of the diagrams below. The objects are placed 2 feet apart. No sound or light may be emitted from the objects and neither must they easily roll i.e. such as a ball but dumbbells are permitted. The objects should be of a size commensurate with that of the dog (small dog – small objects).

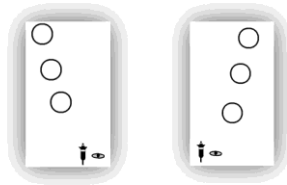

PROCEDURE

The Judge will choose one of the above patterns for the layout of the objects. All dogs will attempt the same pattern.

Upon entering the ring, the handler will give the objects to the Steward who will place the objects at a pre-determined location (chair, table or other suitable location) until needed.

Just prior to the commencement of the exercise the ring steward or Judge will place the 3 objects as required.

When the exercise begins, the handler stands in the handler box.

The handler, with the dog sitting in heel position, will face the objects.

The Judge or steward will have three cards marked 'Left', 'Centre' and 'Right' or some other clearly defined choice.

The handler will draw one card to ascertain which two objects are to be retrieved.

The handler may then cue the dog to retrieve one of the named objects.

Once given the cue, the dog must retrieve the object to the handler and sit in the front position to deliver. The dog does not have to be in the boxed area to deliver.

Praise may be offered only after the dog has successfully retrieved the correct article and is returning to the handler.

Upon the dog's return, the handler may cue the dog to release the object to hand. The procedure is then repeated for the other object.

The exercise is finished when the dog has delivered the final object to hand.

WT6 - Back Away - Elite

-

DESCRIPTION

This exercise demonstrates the dog's ability to walk backwards a short distance in a straight line.

THE PRINCIPLE FEATURES OF THIS EXERCISE ARE FOR THE DOG:-

- To sit or stand in front of the handler box with its back to the back-up box
- When cued by the handler, to move backwards briskly into the back-up box.

COURSE LAYOUT

The shortest distance from the handler box to the back-up box will be 10' (feet).

PROCEDURE

The handler may choose to walk with the dog to the "dog box" to familiarize the dog as to the location of the box and the construction of the box. This may be done at the start of the Class or just prior to each exercise. There will not be any additional time allowed should the handler choose to familiarize the dog to the box.

The exercise begins with the dog facing the handler with the handler facing the back-up box. The dog/handler team will be stationary at the handler's box.

The handler may choose to have the dog in a sit or stand position.

Without prompting by the Judge, the handler will cue the dog to begin backing to the back-up box. The dog should back away from the handler in a brisk manner.

The exercise is complete when the dog is in the dog box.

WT7 - Round the Clock - Elite

DESCRIPTION

This exercise demonstrates the dog's ability and willingness to work away from the handler, to take direction and to make correct choices.

THE PRINCIPLE FEATURES OF THIS EXERCISE ARE FOR THE DOG:-

- To circle three cones as directed by the handler.
- To circle each required cone once only.
- To return to the handler close enough to be touched after circling each cone
- To sit in front of the handler after circling all of the required cones.

COURSE LAYOUT

Six (6) cones will be placed a distance of 7 feet from the centre of the handler box in a circle. The cones will be evenly spaced around the circle. (at 2, 4, 6, 8,10, and 12 o'clock).

The cones will be numbered 1 through 6 with 2" high numbers facing the centre of the circle.

PROCEDURE

The cones to be circled will be posted at ringside prior to the start of the competition. The exercise starts with the Handler standing within the handler box.

All dogs in a class will be required to circle the same cones. The cones may be attempted in any order.

Dog may circle a cone in either a clockwise or anticlockwise direction. No cone should be circled more than once.

The dog returns to the handler each time for a redirection to the next cone. No sit or physical contact is required.

The exercise is finished when the dog has successfully circled the three correct cones, returned to the handler and sat in front.

CONE LAYOUT

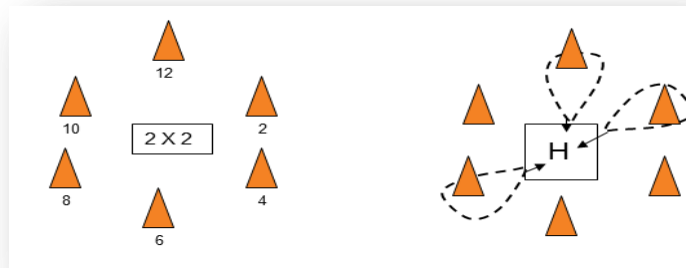
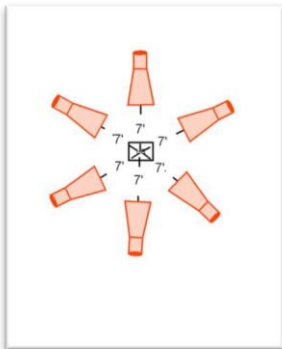

WT8 - Distance Signals - Elite

DESCRIPTION

This exercise demonstrates the dog's ability to understand and perform exercises by signal alone.

THE PRINCIPLE FEATURES OF THIS EXERCISE ARE FOR THE DOG:-

- To sit and stay in position in the dog box whilst the handler walks away.
- To stay in position when the handler turns to face the dog.
- To correctly perform a series of positional changes and other behaviours as indicated.
- To respond to non-verbal cues alone.
- To remain in the box whilst performing the positional changes.
- To return to the box if the position changes causes the dog to leave the box.

COURSE LAYOUT

There will be a handler box and a dog box.
The distance between the two boxes will be 10' (feet).

PROCEDURE

This exercise starts with the dog in heel position in the dog box.
Without prompting from the Judge, the handler cues the dog to sit & stay and then walks 10' (feet) away to the handler box.
The dog remains stationary in the dog box. The handler turns and faces the dog.
The handler then cues the dog to perform the exercises.
Both the handler and the dog remain in their respective boxes. Exercises must be performed in the order specified.
Exercises will be written or typed on slips of cardboard or paper or something similar and placed in a container in such a manner that the writing is not visible to the handler. Handler will draw, prior to entering the ring, to determine which one of the following set of exercises the dog must perform.
Dogs are allowed to leave their box during the required behaviour but should return to the box on completion of the required behaviour. The handler may cue the dog to return to the dog box after the required behaviour.
The exercise is finished when the dog has completed the correct position changes & other behaviours and returned to the box.

POSITION CHANGES (DOG MUST PERFORM ONE OF THE FOLLOWING AS DETERMINED BY THE HANDLER DRAW)

Sit to Stand +Stand to Down + Down to Sit + Sit to Stand+ Named Trick.
Sit to Stand +Stand to Down +Down to Stand + Stand to Sit+ Named Trick.
Sit to Stand +Stand to Sit+ Sit to Down +Down to Stand + Named Trick.
Sit to Stand +Stand to Sit+ Sit to Down +Down to Stand + Back Up Two Steps.
Sit to Down +Down to Stand + Stand to Sit + Sit to Stand+ Named Trick.
Sit to Down +Down to Stand + Stand to Sit + Sit to Stand+ Back Up Two Steps.

WT9 - Retrieve Over Jump - Elite

DESCRIPTION

This exercise demonstrates the dog's ability to retrieve an object** and to jump both going to pick up and returning to deliver an object.

THE PRINCIPLE FEATURES OF THIS EXERCISE ARE FOR THE DOG:-

- To sit at heel position while the handler throws an object.
- To stay in the sit position until cued to jump/retrieve after the object is stationary.
- When cued, to jump over the jump and pick up the object.
- To return over the jump carrying the object.
- To sit in front of the handler close enough that the handler does not have to move his/her feet.
- To relinquish the object to the handler.

COURSE LAYOUT

A handler box or line is placed 10' (feet) away from a standard bar or solid jump (agility or obedience). The jump height will be as stated in the Advanced level of the regular classes.

PROCEDURE

The exercise begins with the handler standing in front of the jump in the handler box or behind the handler line. The handler may stand further back than the 10' line or box but the handler must remain in position.

Dog sits in heel position.

Without prompting from the Judge, the handler will throw the item over the jump while the dog waits in heel position. The item must be thrown at least 8' beyond the jump.

Once given the cue, the dog will go over the jump to get the object, and return to the handler, going over the jump a second time.

The handler may cue the dog to "Jump" then cue the dog to "Get It" and also cue the dog to return over the jump.

The Handler may cue the dog to release the object to hand. Hand and voice signal can be used simultaneously. No finish is required.

The exercise is complete when the dog has delivered the object to hand.

** Any object of the handler's choice may be used. Description: it may not be a toy that rolls when thrown, (such as a ball) and it may not make any internal noise – squeak, growl, etc. If the object is not meant to roll and does so, such as a dumbbell, that is permitted.

WT10 - Scent Discrimination - Elite

DESCRIPTION

The exercise demonstrates the dog's ability to detect one item with the handler's scent from other items without the handler's scent.

THE PRINCIPLE FEATURES OF THIS EXERCISE ARE FOR THE DOG:-

- To sit or stand in position with its back to the object placement area.
- Upon signal from the Judge will either
 - Turn with the handler to face the objects and sit at heel. When cued by the handler (without prompting from the Judge), will briskly move towards the objects and retrieve the object that has been scented by the handler OR.
 - Turn with handler and upon cue from the handler (without prompting from the Judge) will briskly move towards the objects and retrieve the object that has been scented by the handler. (i.e. without having the dog sit after the turn).
- To return briskly and sit in front of the handler to deliver the object close enough that the handler does not have to move his/her feet to accept the object. No finish is required.

COURSE LAYOUT

A handler box or line is required. Three objects are placed in a straight line 10' (feet) from the handler box as indicated in the diagram below and two feet apart.



PROCEDURE

The handler will provide either three (3) clean cloth or three (3) leather gloves of a similar colour. Alternatively regular scent objects as used in obedience competition may also be used. Gloves should be of a size comfortable for the dog to carry. i.e. Small dog - small glove.

Just prior to the commencement of the exercise the Steward will place the objects in a holding location (a chair) provided for the objects, taking care not to leave any scent on the objects. Tongs must be used to remove and place objects.

The handler will stand in the handler box.

The exercise begins with the handler, with the dog in heel position (either the sit or stand), having his/her back to the area where the objects shall be placed to begin the retrieval exercise.

The handler, with hands in sight, will impart his/her scent on one object. Two (2) remaining objects are unscented. The ring steward or Judge will place the 3 objects in the manner described above.

Upon signal from the Judge-the handler may impart the scent again and then cue the dog to retrieve the object No other hand signals or verbal signals may be given to the dog during the retrieve.

Praise may be offered only after the dog has successfully retrieved the correct article and is returning to the handler.

The handler may cue the dog to release the object to hand.

The handler may not turn towards the object of choice, point to the object of choice nor step towards the object. The dog is required to retrieve ONE object only.

Expert Level - Course Layouts

<p>WX1 - Drop, Sit and Stand on Recall</p>	<p>WX2 - Retrieve on the Flat</p>	<p>WX3 - Barrel Racing</p>
<p>WX4 - Retrieve on the Flat</p>	<p>WX5 - Designated Retrieve</p>	<p>WX6 - Back Away</p>
<p>WX7 - Round The Clock</p>	<p>WX8 - Distance Signals</p>	<p>WX9 - Retrieve over Jump</p>
<p>WX10 - Scent Discrimination</p>	<p><i>These diagrams are for illustration purposes only. They are not to scale and do not necessarily display accurately the actual layout</i></p>	

WX1 - Drop & Sit, Call & Stand on Recall - Expert

DESCRIPTION

This exercise demonstrates a dog's willingness to drop on cue at a designated location, then to sit on cue in the same location then to move to another area and stand on cue and then eagerly return to the handler on cue.

THE PRINCIPLE FEATURES OF THIS EXERCISE ARE FOR THE DOG:-

- To stay in position until cued to move forward.
- To move towards the handler until cued to drop.
- To drop in a designated area with both elbows down and behind the appropriate drop line until cued to sit.
- To sit in the designated area with front feet behind the drop line closest to the handler until cued to move forward.
- To move towards the handler until cued to stand.
- To stand in the designated area with front feet behind the drop line closest to the handler until cued to move forward
- To move to the front position when cued and sit close enough that the handler, without moving his/her feet forward, may touch the dog on the head.

COURSE LAYOUT

The total distance from the dog box to the handler box or line will be 20'. Markers are situated 15', 10' and 5' from the handler.

The markers shall be tape or lines on the floor in the path of the dog and handler. The drop/sit zone is between the 15' and 10' markers.

The stand zone is between the 10' and 5' markers.

Sign WX1 shall be placed in such a position that it may be easily seen by the handler but will not interfere with other exercises.

PROCEDURE

The handler sits the dog in the dog box. The handler may cue the dog to stay then proceeds to the handler box or line. The handler turns to face the dog. The handler then, without prompting from the Judge, calls the dog and then cues the dog to drop within the "drop zone". Once the dog has completed the drop, the handler will cue the dog to sit. The handler will then call the dog and then cue the dog to stand within the "stand zone". Once the dog is standing, the handler will call the dog to the front position.

This exercise is completed with the dog sitting in the front position.

WX2 - Retrieve on Flat - Expert

DESCRIPTION

This exercise demonstrates a dog's willingness and ability to retrieve a dumbbell.

THE PRINCIPLE FEATURES OF THIS EXERCISE ARE FOR THE DOG:-

- To sit at heel position and stay there while the handler throws the dumbbell and it comes to rest.
- Upon cue from the handler, to retrieve the object.
- To sit in front of the handler close enough that the handler does not have to move his/her feet to accept the dumbbell.
- To deliver the dumbbell to the hand of the handler.

COURSE LAYOUT

A handler box or line will designate the starting position.

A cone or similar marker may be placed to one side of the desired 'throw' area at a distance of 15' from the handler box or line.

PROCEDURE

The dumbbell shall be a regulation obedience dumbbell and may be made of wood, metal or plastic. The size of the dumbbell should be of a size that suits the dog. The handler may use voice & hand signals simultaneously throughout the exercise.

The handler sits the dog in heel position. If a handler box is utilised, it is not necessary for the dog to be in the handler box but the feet of the dog must be behind the front of the handler box. If a handler line is used, the feet of both the handler and the dog must be behind the line.

The handler may cue the dog to stay.

The handler will throw the dumbbell at least 15' without instruction from the Judge.

When the dumbbell has stopped moving the handler will cue the dog to retrieve the dumbbell.

Praise may be offered only when the dog has successfully retrieved the correct dumbbell and is returning to the handler.

The dog will retrieve the dumbbell and sit in front of the handler to deliver the dumbbell. The exercise is complete when the dumbbell is delivered.

No finish is required.

WX3 - Barrel Racing - Expert

DESCRIPTION

This exercise demonstrates the dog's ability and willingness to work away from the handler and to take direction.

THE PRINCIPLE FEATURES OF THIS EXERCISE ARE FOR THE DOG:-

- To sit at heel position until directed by the handler to circle around a series of cones.
- To circle the cones in the correct direction.
- To return to the handler, close enough to be touched, after all cones have been circled. Note: The handler may rotate in place but must not step out of the handler box.

COURSE LAYOUT

Three cones are placed. Cones 1 and 2 are set 10 feet apart. Cone 3 is set 5 feet from an imaginary line drawn perpendicular from the midway point between cones 1 and 2. The front of the handler box will be 14 (fourteen) feet from cone 3.

PROCEDURE

The exercise will start with the dog sitting in heel position.

The handler may send the dog without prompting from the Judge. Handler may use arms and/or hands or voice as directional cues.

The exercise is complete when the dog has circled all cones correctly and returned close enough to the handler to be touched.

Direction of travel (Handler's Choice)

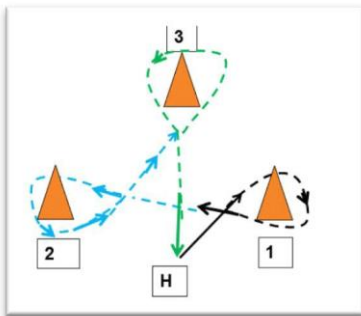

The dog is sent in a clockwise direction around Cone #1, then sent in an anti clockwise direction around cone # 2, then also in an anticlockwise direction around cone # 3 and back to the handler.

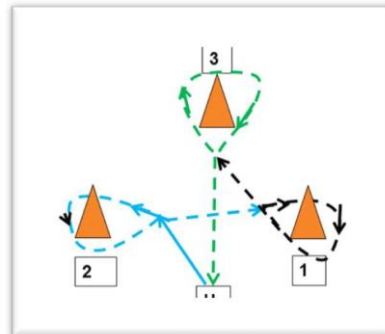

The dog is sent in an anticlockwise direction around Cone #2, then sent in a clockwise direction around cone # 1, then also in a clockwise direction around cone # 3 and back to the handler.

WX4 - Directed Jumping - Expert

DESCRIPTION

This exercise demonstrates the dog's ability to move away from the handler, take instructions and then jump a designated jump and then to repeat the procedure.

THE PRINCIPLE FEATURES OF THIS EXERCISE ARE FOR THE DOG:-

- To sit at heel position and stay there until cued by the handler to move.
- To move between two jumps towards a target area.
- To be in the dog box before turning.
- To sit in the dog box until cued to jump.
- To jump the correct jump.
- To sit close enough in front of the handler so that the handler, without moving his/her feet forward, may touch the dog on the head.
- To repeat the procedure for the second jump.

COURSE LAYOUT

Two Jumps are required for this exercise. These jumps may be either 2 bar jumps, 2 solid jumps, or one of each. The jumps will be placed side by side, in line, with a distance of 15' (feet) between the two nearest jump uprights. A handler box is placed 15' (feet) in front of the jump and midway between the 2 jumps. A dog box is placed midway between the two jumps and 15' (feet) beyond the jumps and 30' (feet) from handler.

PROCEDURE

The handler may choose to walk with the dog to the "dog box" to familiarize the dog as to the location of the box and the construction of the box. This may be done at the start of the Class or just prior to each exercise. There will not be any additional time allowed should the handler choose to familiarize the dog to the box.

The exercise starts at the handler box, with the dog sitting in heel position. Without leaving the box, the handler, without prompting from the Judge, sends the dog away and forward in a direct line between the two jumps, to the dog box 30' (feet) from the handler. Once the dog is in the box, the handler may cue the dog to turn to him/her and may then cue the dog with verbal and hand cues simultaneously to assume a sit, stand or down position in the dog box.

Hand and voice signals may be used simultaneously to indicate, to the dog, which jump to take. Handler may use an additional cue such as "hup" or "over" as the dog approaches the jump.

Handler may turn to face the dog as he/she comes over the designated jump.

Dog is required to sit in front. The handler may cue the dog to sit in front. No Finish is required. The handler may then cue the dog to the heel position for the second part of the exercise.

The dog will be required to be sent each time to the dog box for each of the jumps.

The exercise is completed when the dog has successfully jumped the jumps in the correct order and sits in front of the handler.

CHOICE OF JUMP

The order in which the jumps are to be attempted will be made by the Judge prior to the first dog entering the ring and will be the same order for all dogs.

WX5 - Designated Retrieve - Expert

DESCRIPTION

This exercise demonstrates the dog's ability to retrieve three named objects.

THE PRINCIPLE FEATURES OF THIS EXERCISE ARE FOR THE DOG:-

- To sit at heel position whilst three objects are placed in front of the dog.
- To retrieve the correct object when cued.
- To work briskly although reasonable time is allowed for the dog to select the object.
- To sit close enough in front of the handler so that the handler, without moving his/her feet, can accept the object.

Note: The handler may use verbal & signal cues to designate which object is to be retrieved. No additional cues may be used during the retrieve. The handler may turn towards the object of choice and point to the object of choice. Praise may be offered after the dog has successfully retrieved the correct article and is returning to the handler.

COURSE LAYOUT

Three dissimilar objects or inactive toys of the handler's choice are placed 15 feet in front of the handler as depicted in one of the diagram below. The objects are placed 3 feet apart. No sound or light may be emitted from the objects and neither must they easily roll i.e. such as a ball but dumbbells are permitted. The objects should be of a size commensurate with that of the dog (small dog – small objects).

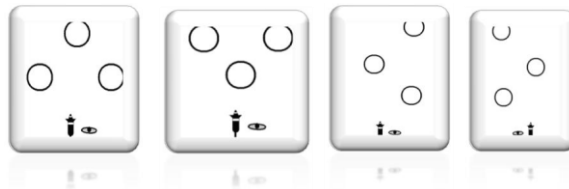

PROCEDURE

The Judge will choose one of the above patterns for the layout of the objects. All dogs will attempt the same pattern.

Upon entering the ring, the handler will give the objects to the Steward who will place the objects at a pre-determined location (chair, table or other suitable location) until needed.

Just prior to the commencement of the exercise the ring steward or Judge will place the 3 objects as required.

When the exercise begins, the handler stands in the handler box.

The handler, with the dog sitting in heel position, will face the objects.

The Judge or steward will have six cards marked 'Left, Centre Right', 'Centre, Right, Left'; 'Right, Centre, Left'; 'Right, Left, Centre'; 'Left, Right, Centre'; 'Left, Centre, Right' or something similar to clearly indicate the order in which the objects are to be retrieved.

The handler will draw one card to ascertain the order in which the objects are to be retrieved. The handler may then cue the dog to retrieve the named objects (one at a time).

Once given the cue, the dog must retrieve the object to the handler and sit in the front position to deliver. The dog does not have to be in the boxed area to deliver.

Praise may be offered only after the dog has successfully retrieved the correct article and is returning to the handler.

Upon the dog's return, the handler may cue the dog to release the object to hand. The procedure is then repeated for the other objects.

The exercise is finished when the dog has delivered the final object to hand.

WX6 - Back Away – Expert

DESCRIPTION

This exercise demonstrates the dog's ability to walk backwards a short distance in a straight line, circle and then back up again.

THE PRINCIPLE FEATURES OF THIS EXERCISE ARE FOR THE DOG:-

- To sit or stand in front of the handler box with its back to the back-up box
- When cued by the handler, to move backwards briskly to a marker.
- To circle either left or right (handler's choice).
- When cued by the handler, to move backwards briskly to the back-up box.

COURSE LAYOUT

The shortest distance from the handler box to the back-up box will be 15' (feet). A marker shall be placed midway between the handler box and the back-up box.

PROCEDURE

The handler may choose to walk with the dog to the "dog box" to familiarize the dog as to the location of the box and the construction of the box. This may be done at the start of the Class or just prior to each exercise. There will not be any additional time allowed should the handler choose to familiarize the dog to the box.

The exercise begins with the dog facing the handler with the handler facing the dog back-up box. The dog/handler team will be stationary at the handler's box.

The handler may choose to have the dog in a sit or stand position.

Without prompting by the Judge, the handler will cue the dog to begin backing to the marker. The handler will then cue the dog to circle either left or right.

Finally, without prompting by the Judge, the handler will cue the dog to begin backing to the back-up box. The dog should back away from the handler in a brisk manner.

The exercise is complete when the dog is in the back-up box

WX7 - Round the Clock - Expert

DESCRIPTION

This exercise demonstrates the dog's ability and willingness to work away from the handler, to take direction and to make correct choices.

THE PRINCIPLE FEATURES OF THIS EXERCISE ARE FOR THE DOG:-

- To circle all cones in order.
- To circle each required cone once only.
- To return to the handler close enough to be touched after circling each cone
- To sit in front of the handler after circling all of the required cones.

COURSE LAYOUT

Six (6) cones will be placed a distance of 10 feet from the centre of the handler box in a circle. The cones will be evenly spaced around the circle (at 2, 4, 6, 8, 10, and 12 o'clock).

The cones will be numbered 1 through 6 with 2" high numbering with the numbers facing the centre of the circle.

PROCEDURE

The exercise starts with the Handler standing within the handler box.

All cones will be circled starting with the cone at 2 o'clock and continuing in a clockwise direction. Dog may circle a cone in either a clockwise or anticlockwise direction.

No cone should be circled more than once.

The dog returns to the handler each time for a redirection to the next cone. No sit or physical contact is required.

The exercise is finished when the dog has successfully circled all cones correctly, returned to the handler and sat in front.

CONE LAYOUT

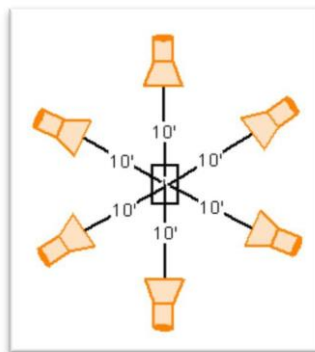

WX8 - Distance Signals - Expert

DESCRIPTION

This exercise demonstrates the dog's ability to understand and perform exercises by signal alone.

THE PRINCIPLE FEATURES OF THIS EXERCISE ARE FOR THE DOG:-

- To sit and stay in position in the dog box whilst the handler walks away.
- To stay in position when the handler turns to face the dog.
- To correctly perform a series of positional changes and other behaviours as indicated.
- To respond to non-verbal cues alone.
- To remain in the box whilst performing the positional changes.
- To return to the box if the positional changes causes the dog to leave the box.

COURSE LAYOUT

There will be a handler box and a dog box.
The distance between the two boxes will be 10' (feet).

PROCEDURE

This exercise starts with the dog in heel position in the dog box.
Without prompting from the Judge, the handler cues the dog to sit & stay and then walks 10' (feet) away to the handler box.
The dog remains stationary in the dog box. The handler turns and faces the dog.
The handler then cues the dog to perform the exercises.
Both the handler and the dog remain in their respective boxes. Exercises must be performed in the order specified.
Exercises will be written/typed on slips of cardboard or paper or something similar and placed in a container in such a manner that the writing is not visible to the handler. Handler will draw, prior to entering the ring, to determine which one of the following set of exercises the dog must perform.
Dogs are allowed to leave their box during the position changes but should return to the box on completion of them. The handler may cue the dog to return to the dog box after the changes of position.
The exercise is finished when the dog has completed the correct position changes & other behaviours and returned to the box.

POSITION CHANGES (DOG MUST PERFORM ONE OF THE FOLLOWING AS DETERMINED BY THE HANDLER DRAW)

Sit to Stand +Stand to Down + Down to Sit + Sit to Stand + 2 Named Tricks.
Sit to Stand +Stand to Down + Down to Stand + Stand to Sit+ 2 Named Tricks.
Sit to Stand +Stand to Sit+ Sit to Down +Down to Stand + Back Up two steps +2 Named Tricks.
Sit to Stand +Stand to Sit+ Sit to Down +Down to Stand + 2 Name Tricks.
Sit to Stand +Stand to Sit + Sit to Down +Down to Stand + 2 Named Tricks.
Sit to Stand +Stand to Sit+ Sit to Down +Down to Stand + Back Up Two Steps + 2 Named Tricks.
Sit to Down +Down to Stand + Stand to Sit + Sit to Stand+ + 2 Named Tricks.
Sit to Down +Down to Stand + Stand to Sit + Sit to Stand+ Back Up Two Steps + 2 Named Tricks.

WX9 - Retrieve Over Jump - Expert

DESCRIPTION

This exercise demonstrates the dog's ability to retrieve an object** and to jump both going to pick up and returning to deliver an object.

THE PRINCIPLE FEATURES OF THIS EXERCISE ARE FOR THE DOG:-

- To sit at heel position while the handler throws an object.
- To stay in the sit position until cued to jump/retrieve after the object is stationary.
- When cued, to jump over the jump and pick up the object.
- To return over the jump carrying the object.
- To sit in front of the handler close enough that the handler does not have to move his/her feet.
- To relinquish the object to the handler.

COURSE LAYOUT

A handler box or line is placed 10' (feet) away from a standard bar or solid jump (agility or obedience). The jump height will be as stated in the Advanced level of the regular classes.

PROCEDURE

The exercise begins with the handler standing in front of the jump in the handler box or behind the handler line. The handler may stand further back than the 10' line or box but the handler must remain in position.

Dog sits in heel position.

Without prompting from the Judge, the handler will throw the item over the jump while the dog waits in heel position. The item must be thrown at least 10' beyond the jump.

Once given the cue, the dog will go over the jump to get the object, and return to the handler, going over the jump a second time.

The handler may cue the dog to "Jump" then cue the dog to "Get It" and also cue the dog to return over the jump.

The Handler may cue the dog to release the object to hand. Hand and voice signal can be used simultaneously. No finish is required.

The exercise is complete when the dog has delivered the object to hand.

** Any object of the handler's choice may be used. Description: it may not be a toy that rolls when thrown, (such as a ball) and it may not make any internal noise – squeak, growl, etc. If the object is not meant to roll and does so, such as a dumbbell, that is permitted.

WX10 - Scent Discrimination - Expert

DESCRIPTION

The exercise demonstrates the dog's ability to detect two items with the handler's scent from one other item with a foreign scent.

THE PRINCIPLE FEATURES OF THIS EXERCISE ARE FOR THE DOG:-

- To sit or stand in position with its back to the object placement area.
- Upon signal from the Judge will either
 - Turn with the handler to face the objects and sit at heel. When cued by the handler (without prompting from the Judge), will briskly move towards the objects and retrieve the object that has been scented by the handler OR.
 - Turn with handler and upon cue from the handler (without prompting from the Judge) will briskly move towards the objects and retrieve the object that has been scented by the handler. (i.e. without having the dog sit after the turn).
- To return briskly and sit in front of the handler close enough that the handler does not have to move his/her feet to accept the object., to deliver the object No finish is required.
- Then repeat the procedure for the second object.

NOTE: During this exercise extra cues are not allowed. Praise may be offered after the dog has successfully retrieved the correct article and is returning to the handler.

COURSE LAYOUT

A handler box or line is required. The first object is placed 10' (feet) from the handler box as indicated in the diagram below and the others two feet apart.



PROCEDURE

The handler will provide either three (3) clean cloth or three (3) leather gloves of a similar colour. Alternatively regular scent objects as used in obedience competition may also be used. Gloves should be of a size comfortable for the dog to carry, i.e. Small dog - small glove.

Just prior to the commencement of the exercise the Steward will place the objects in a holding location (a chair) provided for the objects, taking care not to leave any scent on the objects. Tongs must be used to remove and place objects.

The handler will stand in the handler box.

The exercise begins with the handler, with the dog in heel position (either the sit or stand), having his/her back to the area where the objects shall be placed to begin the retrieval exercise.

The handler, with hands in sight, will impart his/her scent on two objects. The other object is scented by the Judge. The ring steward or Judge will place the 3 objects in the manner described above.

Upon signal from the Judge-the handler may impart the scent again and then cue the dog to retrieve the first object. No other hand signals or verbal signals may be given to the dog during the retrieve.

Praise may be offered only after the dog has successfully retrieved the correct article and is returning to the handler.

The handler may cue the dog to release the object to hand. The dog is then sent to retrieve the second object. The dog must retrieve two objects

JUDGING:

Training in the Ring

Training in the ring is not permitted.

In the Working Rookie and Elite Levels one repeat of each station is allowed. The Judge should indicate to a handler if an exercise has not been performed to obtain a PASS or if the exercise is a PASS.

It is the judge's responsibility to tell the competitor to "move on" to the next attempt at the exercise or to the next exercise after the second attempt.

Scent Discrimination

Should the dog fail to retrieve the correct article on the first send away, the judge will advise the handler who will turn away from the articles while the judge replaces the incorrectly retrieved article. The handler may then send the dog again. Should the dog fail to retrieve on the second send, **the exercise is finished and judge will tell the competitor to "move on" to the next exercise.**

If the dog picks up an incorrect article, drops it immediately and then picks up the correct article WITHOUT any additional cue from the handler then the dog has completed the exercise.

Training in the ring is not permitted. The exhibitor must move on to the next exercise immediately. i.e. They may not go to the object of choice and get the dog to retrieve it. The handler may not at anytime leave the handler box or line to help the dog.

Directed Jumping

Handler sends dog to the box. The handler may give more than one command but if the dog, after several commands, to go to the box returns to the handler or just keeps being indecisive, the Judge should indicate to a handler that the first attempt should be terminated. The handler may then attempt the exercise a second time or move on to the next station. Training in the ring is not permitted. The exhibitor must move on to the next exercise immediately. i.e. The handler may not go with the dog to show he/she where the box is. The handler may not at anytime leave the handler box or line to help the dog.

Object Discrimination

The handler sends the dog and may repeat the object name several times on the way out.

The handler may use verbal &/or signal cues, depending on the Working Level, to designate which object is to be retrieved. No additional cues may be used during the retrieve. Should the dog pick up the wrong article the Judge should indicate to a handler that the first attempt should be terminated or the exercise has not been performed to obtain a PASS and to proceed to second attempt The handler will re draw a card and send again or if 2nd attempt has been made, **the judge will tell the competitor to "move on" to the next exercise.**

Should the dog fail to retrieve the correct article on the first send away, **the judge will indicate to a handler that the first attempt should be terminated.** The handler may then turn his or her back to the articles while the judge replaces the article that was incorrectly retrieved. Once the dog has failed to retrieve the correct article on the second send away, **the judge will tell the competitor to "move on" to the next exercise.** The handler MUST move on to the next exercise immediately. The handler may not at any time leave the handler box or line to help the dog.

Signal Exercises

i.e. Sit to Stand-Stand to Down-Stand to Stand Spin Left

Dog Sits- Stands-Downs but does not move into the stand on the first command...the signal can be repeated but once the dog has given another behavior other than the stand: the dog sits instead of stands, the Judge should indicate to a handler that the first attempt should be terminated or the exercise has not been performed to obtain a PASS and to proceed to the second attempt. The judge will indicate a Pass on the second attempt **or tell the competitor to "move on" to the next exercise.** (Expert there is no second attempt).

Training in the ring is not permitted. The exhibitor must move on to the next exercise immediately.

The handler may not at any time leave the handler box or line to help the dog.